

REV.	ECN NO.	LOCAS.	DESCRIPTION	DATE	DESIGN
A0			RELEASE TO CUSTOMER		HANG

PIN	∅1.65	∅2.0	∅2.35	∅2.5
APPD		✓		

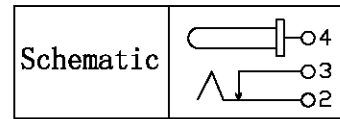

### SPECIFICATION

1. Current Rating: 1.0Amp
2. Operation Voltage: 30V
3. Contact Resistance: 30m Ohms Max
4. Insulation Resistance: 100M Ohms Min
5. Dielectric Withstanding Voltage: 500VAC
6. Mating and Unmating Force: 3 to 20N
7. Life: 5000 Cycles

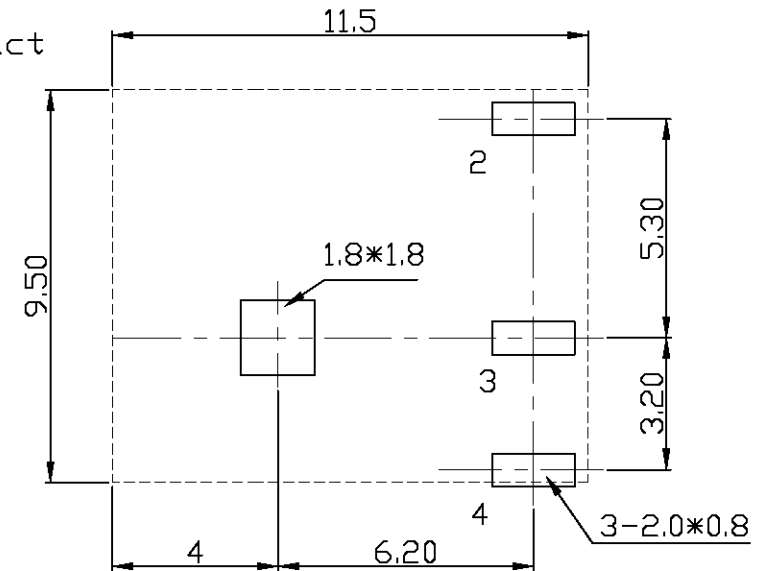
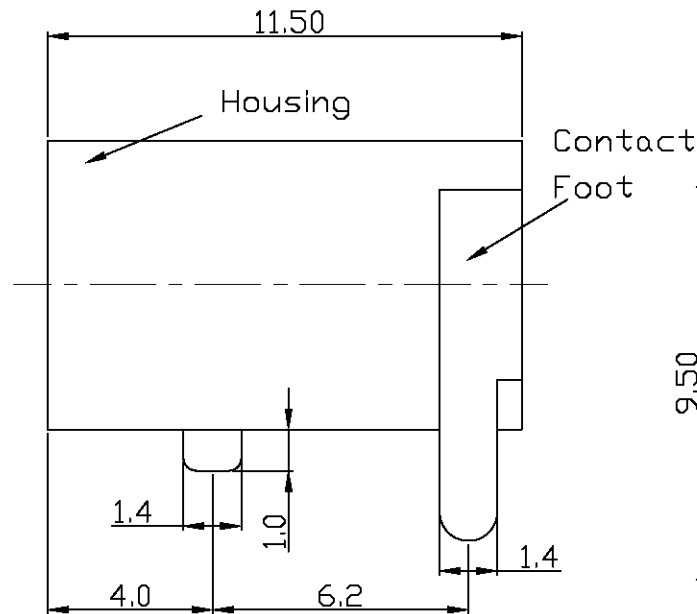
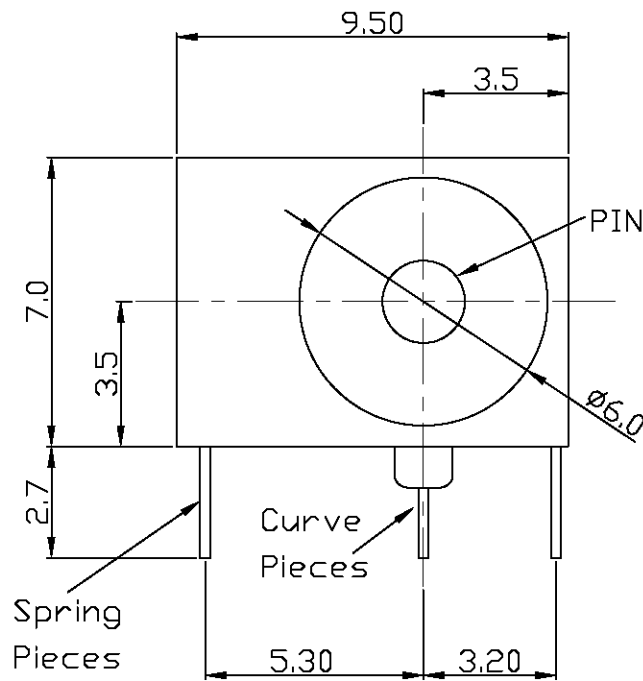

### PCB LAYOUT

5	pin	H59 Brass	1	Sn-Plated
4	Contact Foot	Brass	1	Ag-Plated
3	Curve Pieces	Brass	1	Ag-Plated
2	Spring Pieces	Bronze	1	Ag-Plated
1	Housing	PBT	1	Black
ITEM	PART	MATERIAL	QTY	REMARK

# LASTAR

Lastar Technology CO., LTD

DRAW NO.		DATE	DRAW NAME: DC POWER JACK		
DESIGN	HANG	070505	P/N NO. DC-090044-20		
CHECK	WANGCM	070506	FILE:		
APPROVED	HUYX	070506	MODEL:		
			UNIT: mm	SHEET: N/A	REV. A0
					SCALE N/A