

REV.	ECN NO.	LOCAS.	DESCRIPTION	DATE	DESIGN
AO			RELEASE TO CUSTOMER		HANG

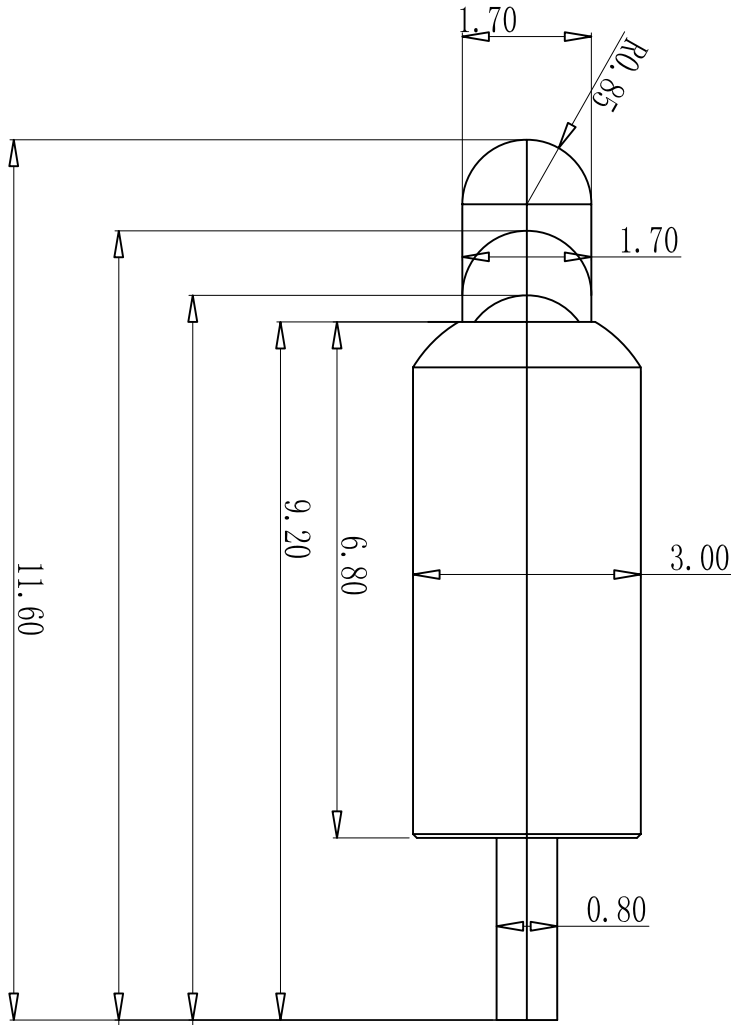
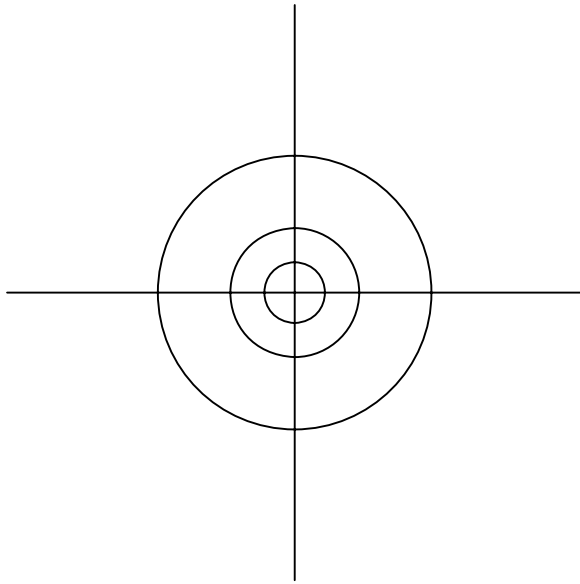

compress 9.55mm, elasticity of 330gf
the best testing of length is compress 10.4mm, elasticity of 230gf

LASTAR

Lastar Technology CO., LTD

DRAW NO.		DATE	DRAW NAME:		
DESIGN	HANG	070506	顶针弹力压缩示意图		
CHECK	WANGCH	070506	P/N NO.	FILE:	MODEL:
APPROVED	HUYX	070506	UNIT: mm	SHEET: N/A	REV. AO
			SCALE	N/A	